

Operating Manual

Style FX 100/400



Table of contents

Introduction	2
Declaration of conformity, disposal and recycling, CE marking	3
Safety notice and precaution	4
Operating instructions	5
Control Panel	6
Switch and Fuse	7
Modelling Light	8
Digital power display, Photo-cell	9
Synchronisation, Wireless Remote control and flash triggering	10
Acoustic signal	10
DVD, «The beginner's guide to light»	11
Troubleshooting	7, 11
Technical Data	12
Elinchrom Accessories	13
Guarantee	14

PS: Technical data subject to change.

The listed values are guide values which may vary due to tolerances in components used.

Introduction

The Elinchrom Style FX is manufactured by Elinca S.A. CH -1020 Renens/Switzerland

Dear Photographer,

Thank you for buying your Style FX compact flash unit.

All Elinchrom products are manufactured using the most advanced technology. Carefully selected components are used to ensure the highest quality and the equipment is submitted to many controls both during and after manufacture. We trust that it will give you many years of reliable service.

All Style FX flash units are manufactured for the studio and location use of professional photographers. Only by observance of the information given, can you secure your warranty, prevent possible damage and increase the life of this equipment.

Style 100FX - 400FX

The quality of light and exceptional performance is the result of long research, application of demanding principles, the long experience of ELINCHROM in lighting products for the studio and the utilization of the latest technology in this area.

Totally integrated to the range of the ELINCHROM flashes, the Style 100FX - 400FX units maintain the traditional look and function that is ELINCHROM.

The control provides continuously variable adjustment of the modelling lamp and the flash power with precision over 5 f-stop, from full power 1/1 to 1/16 th.

FCC Class B Compliance Statement

Note:

This equipment has been tested and found to comply with the limits for a class B digital device, pursuant to Part 15 of the FCC Rules and meets all requirements of the Canadian Interference-Causing Equipment Regulations. These limits are designed to provide reasonable protection against harmful interference in a residential installation. This equipment generates, uses, and can radiate radio frequency energy and, if not installed and used in accordance with the instruction manual, may cause harmful interference to radio communications. However, there is no guarantee that interference will not occur in a particular installation. If this equipment does not cause harmful interferences to radio or television reception, which can be determined by turning the equipment off and on, the user is encouraged to correct the interferences by one or more of the following measures:

- Reorient or relocate the receiving antenna.*
- Increase the separation between the equipment and receiver.*
- Connect the equipment into an outlet on a circuit different from that to which the receiver is connected.*
- Consult the dealer or an experienced radio/TV technician for help.*

ELINCA S.A. is not responsible for any radio or television interference caused by unauthorised modifications of this equipment or the substitution or attachment of connecting cables and equipment other than those specified by ELINCA S.A. The correction of interference caused by such unauthorised modification, substitution or attachment will be the responsibility of the user.

Declaration of conformity

This device complies with Part 15 of the FCC Rules. Operation is subject to the following two conditions:

1. This device may not cause harmful interference.
2. This device must accept any interference received, including interference that may cause undesired operation.

Product name:	Professional Studio Flash unit
Trade name:	ELINCHROM
Model number(s):	Style FX 100/400
Name of responsible party:	Elinca S.A Av. De Longemalle 11 1020 Renens / Switzerland
Phone :	+41 21 637 2677
Fax:	+41 21 637 2681

We, ELINCA S.A., hereby declare that the equipment bearing the trade name and model number specified above was tested conforming to the applicable FCC rules, and that all the necessary steps have been taken and are in force to assure that the production units of the same equipment will continue to comply with the Comissions requirements.

Disposal and recycling



This device has been manufactured to the highest possible degree from materials which can be recycled or disposed of in a manner that is not enviromentally damaging. The device may be taken back after use to be recycled, provided that it is turned in a condition that is the result of normal use. Any components not reclaimed will be disposed of in a environmentally acceptable manner.

If you have any question on disposal, please contact your local office or your local ELINCHROM agent (check our website for a list of all ELINCHROM agents world wide).

CE marking



The shipped version of this device complies with the requirements of ECC directives 89/336/ECC «Electromagnetic compatibility» and 73/23/ECC «Low voltage directive».

Notational Conventions

The meaning of the symbols and fonts used in this manual are as follows:



Pay particular attention to text marked with this symbol.
Failure to observe this warning endangers your life, destroys the device, or may damage other equipment



Supplementary information, remarks, and tips follow this symbol.
Text which follows this symbol describes activities that must be performed in the order shown.

«Quotation marks» indicate names of chapters or terms

Safety notice

According to safety regulations, we draw your attention to the fact that these electronic flash units are not designed for use outdoors, in damp or dusty conditions and should not be used after being exposed to sudden temperature changes causing condensation. They must always be connected to an earthed (grounded) mains supply.

On no account should any object be inserted into the ventilation holes.

The units may retain an internal charge for a considerable time even though disconnected from the power supply.

- Do not use in restricted areas (like hospitals, etc.).
- Do not use in explosive environments.

Flash Tubes and Modelling lamps

- Flash tubes and modelling lamps in use are very hot!
- Never touch a flash tube or lamp before the unit cooled down and is disconnected from the mains (min 30mn).
- Do not fire flashes from short distance (less than 1m) directed to a person and avoid looking directly into the flashlight!
- Keep (min 1m) distance to flammable materials.
- Keep generally distance to operating units.

Transport

- Transport the flash unit with care and only in its original packaging or another corresponding packaging fit to protect it against knocks and jolts.
- Transport only in complete discharged conditions. Wait a minimum 30 minutes after removing from mains supply before packaging and transportation.
- Never drop the flash unit (danger of glass breakage)

Power cable

To guarantee safe operation, use the cable supplied.

- The cable has to be HAR-certified or VDE-certified. the mark HAR or VDE will appear on the outer sheath.
- The cable set must be selected according to the rated current for your flash unit.
- Do not use a spider box to connect one or more flash units.



- Flash systems store electrical energy in capacitors by applying high voltage.
- For your safety, never open or disassemble your flashes.
- Only an authorised service engineer should open or attempt to repair the units.
- Internal defect charge capacitors may explode whilst the unit is in use, never switch on a proper working flash unit.

Before you start !

The Style FX are adapted for operation on 190-260V/50-60Hz.

Before connecting for the first time, check to make sure that your modelling lamp coincides with the voltage line.

They must always be connected to an earthed (grounded) mains supply.

All Style FX units have a bayonet mount and locking ring reflector fitting, for fixing all Elinchrom and Prolinca accessories.

Mount the unit securely to a suitable stand or support.

Remove the black protective cover (note: first turn the locking ring A as shown, then rotate the black cap cover B in the same direction). Fitting a reflector or accessory is the reverse of this action. DO NOT operate the unit without first removing the black protective cover.

Operating instructions

1. Check that the modelling lamp voltage is correct.
2. Check that the mains switch (3) is in the OFF ("O" position).
3. Insert mains cable to the MAINS INLET (1) and connect to a FULLY EARTHED OUTLET
4. Connect the synchro cord to the socket (6).
5. Using the mains SWITCH (3) and switch the unit ON ("I" position).
6. Select the power with the touch pad (11 - 12)



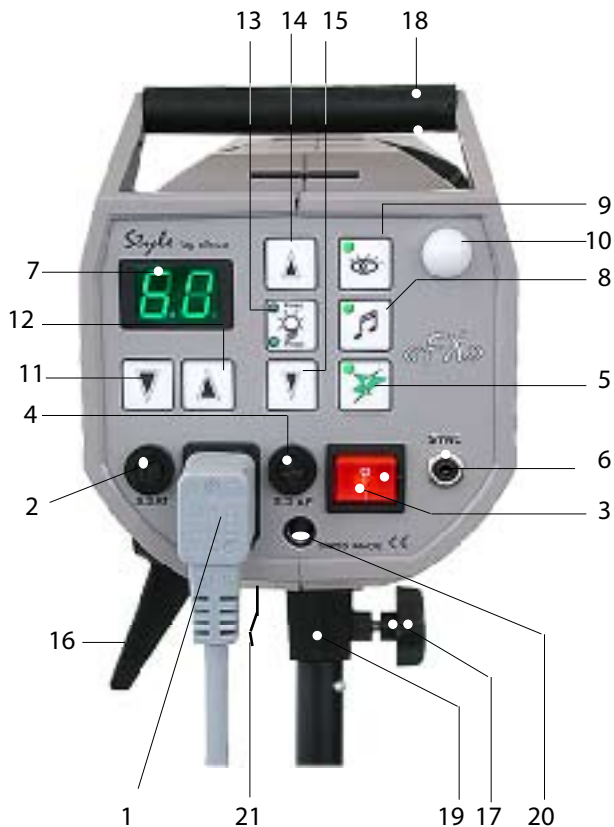

Overview of controls

- | | |
|--|--|
| <ul style="list-style-type: none"> 1. Mains inlet socket 2. Mains fuse (slow blow) 3. Mains illuminated on/off switch 4. Modelling fuse (fast blow) 5. Open-flash 6. Synchro-sockets, Amphenol + jack 3.5 mm 7. Digital power display and charge/discharge indicator 8. Acoustic recharging signal (Beep) 9. Slave cell switch on/off 10. Photocell receptor 11. Power adjustment in 1/10 f-stops, with ADF | <ul style="list-style-type: none"> 12. + Power adjustment in 1/10 f-stops 13. Modelling lamp switch (on/off free or prop) 14. + Modelling power control 15. - Modelling power control 16. Tilt head clamp 17. Knurled clamp screw 18. Handle 19. Stand 5/8-inch socket 20. Umbrella tube (only for EL umbrellas, diameter 7 mm) 21. Supplementary locking for others umbrellas |
|--|--|

Mains Supply

With the MAINS SWITCH (3) switched off ("O" position), firmly push in the plug of the original ELINCHROM mains cord into the mains socket (1).

Mains Switch

The switch should light up when the compact is switched on ("I" position).
(Switch off before removing the mains cord).

Troubleshooting

If the on/off switch (3) is ON ("I" position) but not illuminated, switch off the unit and check the mains fuse (2).

If failed replace with the correct fuse and switch ON the unit.

This unit is protected by a thermal circuit breaker to avoid overheating.

Should this occur, the unit turns off automatically and cannot be fired.

After a break for cooling, the flash will be ready again for operation.

See page 11: Troubleshooting

This equipment is not user serviceable and contains high voltages which are dangerous.

In the event of failure, please return the unit to an authorized Elinchrom service station.

Mains Fuse

Standard type 5 x 20 mm, (use only tempered fuse)

8 AT (code 19022) for Style 100FX and Style 400FX

Note: Before exchanging a blown fuse, switch off the unit and remove mains cable. Depress and turn the fuse holder anti-clockwise 1/8th, turn and remove it. If the new fuse blows immediately upon reconnection, return the unit to an ELINCHROM service centre for a check-up.

(Please don't forget to check the correct rating of the fuse !).

Fuse for modelling light

Fast type 5 x 20mm, 4 AF

Switch off the unit and replace the blown fuse with a new one of the correct rating.

The fastblow fuse will protect the triac of the modelling lamp circuit, the lamp and therefore the flash tube.

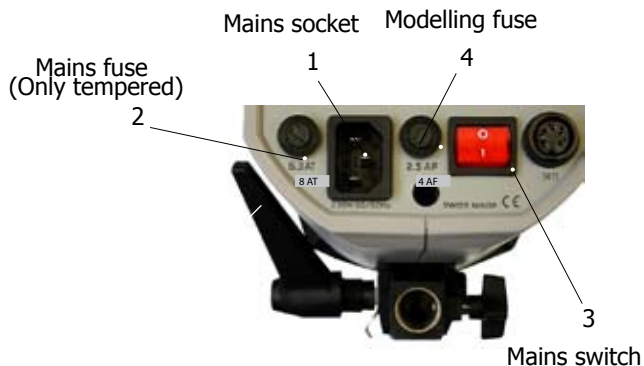

Modelling Light

The touch pad (14) controls the modelling lamp on/off and the proportional light.

Select the power with the touch pad (15). The modelling light output (100%) is achieved when the power value is set to maximum.

Proportional modelling lamp, is set when the position "PROP" is selected (led is illuminated), the light output is proportional to the selected flash power.

For all types of Style FX compact flash units, use maximum 200 - 250W modelling lamps

Modelling lamps and fuse (230V Version)

Unit	Modelling lamp	Code	Socket	Fuse	Code
Style 100FX	100W krypton	23002	E27	2.5AF	19033
Style 400FX	100W krypton	23002	E27	2.5AF	19033
Option:	150W halostar	23035	E27	2.5AF	19033
Option:	200W halogen	23034	GX 6,35	2.5AF	19033

Note: lamp socket adapter E27 to GX 6.35, code 23101

This adaptor allows the use of the halogen lamp 200W, GX 6.35 (code 23034) in the Style 100 FX and 400 FX units.

230V Modelling lamp options:



23033



23101



23035

If the modelling lamp does not illuminate, this may be due to the following:

- 1. The filament is broken after long use *(replace lamp and fuse)*
- 2. The filament is broken after shock *(replace lamp and fuse)*
- 3. An internal component failure, *(return the unit to customer service)*

** Action required:*

14



On/Off
proportional

15



Increase

15



Decrease

Digital power display

The actual flash power is shown in a f-stop compatible format.

The power range is 5 f-stops. The digital display, provides continuous power indication of the flash and modelling lamp. The controls cover a continuous output range from full power 1/1 to 1/16th in 1/10th, f-stop intervals.

During charging or discharging, the display "flashes".

Note:

The "Style 100 FX and 400 FX" units have an integrated discharge system, protected by a thermic switch.

To avoid overheating, lower power settings of more than 2f-stop, can be discharged manually by releasing the flash with the «Test» touch button.

Photocell

The photocell is activated when the green LED (on the touch pad 9) is illuminated.

When switched ON, the unit can be remotely triggered by another flash unit !

The Style FX photocell is specially designed to work under ambient light conditions in your studio.

Direct light or other strong light sources may reduce the sensitivity of the cell.

In difficult situations e.g. blinding, sunlight or obstacles, the additional cell with 5 m cord (extensions available) solves most problems.



Cordless flash control

EL-Skyport triggers flashes without sync cords over a distance of approximately 100 m.

Further detailed information please find under :

www.elinchrom.com / Products / RX Multi Remote

EL-Skyport Universal Set

(19360)



Universal receiver



Transmitter

Synchronisation socket

The standard socket 3.5 mm mini-jack (6).

N.B. Do not link ELINCHROM units by cable to other manufacturers sync outlets.

ELINCHROM uses the low voltage (5V) for security reasons.

Open flash "Test"

Having pressed the touch pad to release a flash, the green «READY» light will appear again once the unit is recharged. If the green light does not appear the charge system could be defective.

Please contact and send to an authorized Elinchrom service.

Audible recharge signal

Select the function with the touch pad (8), the green indicator appears.

Once recycled an acoustic signal indicates that the compact unit is ready.

Test and Ready



5

Beep



8

Troubleshooting

1. The mains switch (3) is ON ("I" position), but does not light up:

- Switch OFF the unit and change the mains fuse (2)
- Use only time-lag fuse (16 AT), corresponding to the Style FX model

2. The switch (3) is lit, the open flash ready is lighting up but does not function.

- The flashtube in the flashhead may be faulty
- You cannot change the flashtube by yourself! => please return the unit to an authorised Elinchrom service.

3. The ON/OFF switch (3) is lit but the open flash signal (6) is not lit

- Temporary break for overheating, caused by fast flash sequences or ventilation slots obturated
- Fan cooling defective => the unit turns off automatically and cannot be fired any more. After a break for cooling, the flash is ready again for operation.
- If after several minutes of break for cooling the ready signal (6) is not lit, the cause could be a component failure. However, high voltage may remain on the capacitor circuits. => DO NOT ATTEMPT TO REPAIR THE UNIT. In this case please send the unit to an authorised Elinchrom station.

Training with Elinchrom lighting

The Beginner's Guide To Light / 72404

Only in English available.

Your DVD Guide to better pictures, show how easy studio photography can be.

Learn about flash units and why studio flash is just the better light source for portrait and universal photography.

Setting up and controlling flash lights and how to use umbrellas, softboxes, snoots and grids. Have a look and enjoy the passion of photography. Presented by Chris Burfoot.

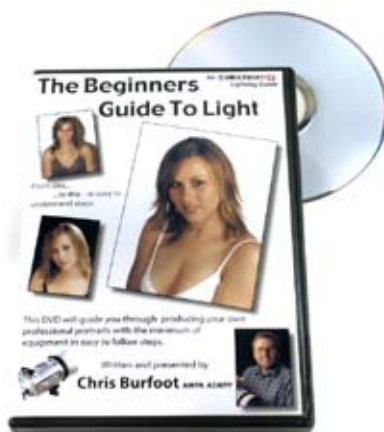

Features

- Mains switch
- Controls for: modelling on/off, cell on/off, acoustic signal on/off.
- Flash and modelling power control.
- «X» synchro jack socket 3,5 mm.
- Socket for Plug-In remote control.
- Mains inlet socket and two fuses (Mains and modelling).
- Locking bayonet ring for accessory and reflector fitting
- Tilthead whit 5/8" - inch stand socket
- Thermal safety
- Halogen modelling lamp 100W, with E27 fitting, or optional alternative *200W/GX6.35 with adaptator code 23101.
- Silent fan cooling
- Auto dumping function. Automatic discharge of flash power
- Central umbrella tube plus external fitting
- Acoustic recharging signal
- Mains cable
- Synchro cord of 5m (jack 3.5mm plug)
- Protective cover
- Total compatibility with all Elinchrom accessories
- Very fast recycling time
- Very short flash duration

Technical data		100FX	400FX
Flash power	J(Ws)	100	400
Power supply	V	200/260	200/260
F-stop, 1m, 100 ISO, with reflector 48°		32,5	64,5
Control range	J(Ws)	6.25-100	25-400
Recycling time (230 V)	s	0,2-0,5	0,3-1,2
Flash duration (t 0,5) 1/1	s	1/1800	1/900
(t 0,5) 1/16	s	1/1150	1/550
Modelling output	W	100	100
Voltage across sync cable	V	5	5
Connected load A/VA	(W)	6.3/1638	6.3/1638
Radio interference suppressiv CE-IEC 491			
Dimension length x diam.	cm	21x14	21x14
Weight	kg	1,55	1,9

Tolerances and specifications conforming to IEC and CE standards. Technical data subject to change without notice.

Elinchrom Accessories

		code		
Reflectors	Wide angle ø 16 cm /90°	26143		
	Compact ø 18 cm /60°	26144		
	Standard ø 21 cm /50°	26141		
	Mini soft ø 44 cm silver	26166		
	Mini soft ø 44 cm white	26168		
	Snoot & Grid	26061		
	Grids	Grid set for reflector 18 cm	26427	
		Grid set for 21 cm	26135	
Filters	Set of 10 color/mixed filters for 21 cm x 21 cm	26051		
	Polarizing filter 21 cm	26243		
Lightbanks ROTALUX	Square 70 x70 cm	26244		
	Square 100 x100 cm	26178		
	Strip 95 x 35 cm	26179		
	Rectangular 130 x 50 cm	26180		
	Octagonal 100 cm	26181		
	Octagonal 135 cm	26183		
Umbrellas	White diam. 85 cm	26184		
	Silver diam. 83 cm	26372		
	Translucent diam. 85 cm	26350		
Spots	Zoom Spot 18° - 36°	26371		
	Mini spot	26481		
Stands	Stand 85-235cm	26420		
	Stand Master 109-385 cm	30101		
Bags	Carrying bag for 2 mono compacts	30149B		
	Carrying bag for 2 stands + 2 umbrellas	33197		
Case	Carrying case for 3 mono compacts	33220		
Trigger accessories	IR flash remote	33209		
	Universal Set (1x Transmitter, 1x Universal Receiver and cables)	40203		
Synchro cords	Synchro cable 5 m length camera to flash units (jack 3.5 mm)	19360		
	Modelling lamps (90/140V)	Quartz Halogen, Socket E27-150 W	11084	
		Quartz Halogen, GX 6,35 -150 W	23019	
Quartz Halogen, GX 6.35 - 200W		23031		
Modelling lamps (190/260V)	Kypton/photo, Socket E27-100W	23033		
	Quartz Halogen, Socket E27-150 W	23002		
	Quartz Halogen, GX 6.35 - 200 W	23035		
		23034		

GUARANTEE

This ELINCHROM product will be repaired free of charge by the vending agent if during a period of 24 months from date of purchase its working order is impaired through a manufacturing or material defect. The faulty product should be immediately sent to the authorized dealer or ELINCA agent. This guarantee is not valid for equipment which has been misused, dismantled, modified or repaired by persons not belonging to the ELINCA distribution network. It does not cover flash tubes, lamps and the normal ageing of capacitors. No responsibilities can be accepted for damage resulting from unsatisfactory operation of the equipment, such as wasted film or other expenses.



Please „register“ your Elinchrom product online, under
www.elinchrom.com > Downloads > Product Registration

In case you cannot register your Elinchrom unit via internet, please fill in the Guarantee card and post it to Elinca.

Please return this registration card directly to	:	elinca sa
Diese Registrierkarte bitte direkt zurücksenden an	:	P.O. Box 458
Veuillez retourner cette carte d'enregistrement directement à	:	Avenue de Longemalle 11
Vi preghiamo di far pervenire questa cartolina di iscrizione direttamente a	:	CH-1020 Renens
Por favor envie esta carta de registro directamente	:	Switzerland

Elinchrom model	:	
Elinchrom modèle	:	
Elinchrom modell	:	
Modello di Elinchrom	:	
Modelo de Elinchrom	:	N°

Date of purchase	:	Dealer	:
Datum des Kaufs	:	Händler	:
La date d'achat	:	Négociant	:
La data di acquisto	:	Il distributore	:
La fecha de la compra	:	El comerciante	:

Your full name and address	:
Ihr voller Name und redet an	:
Votre nom complet et adresse	:
Il suo nome pieno ed indirizza	:
Su nombre y apellidos y dirige	:



www.elinchrom.com